

**Characteristics**

Pilot operated relief valves of the series VBY consist of a pilot with manual adjustment and a spool type main stage. The valves need to be externally drained.

The series VBY NG10 can also be used as pressure sequence valve, because of the high pressure capability in the outlet port and the external drain port. In this case the external drain port Y has to be used.

**Features**

- Subplate mounting acc. to ISO 5781
- Main stage spool type
- Pilot stage seated type
- 4 pressure stages
- 2 adjustment modes:
  - screw with hexagon socket
  - cylinder lock

4



VBY\*A06



VBY\*A10

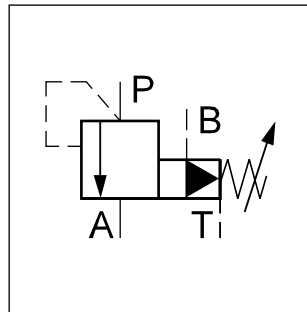

VBY\*A06

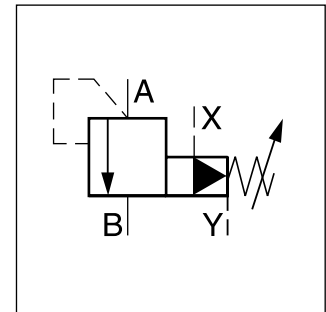

VBY\*A10

**VBY\*A06**

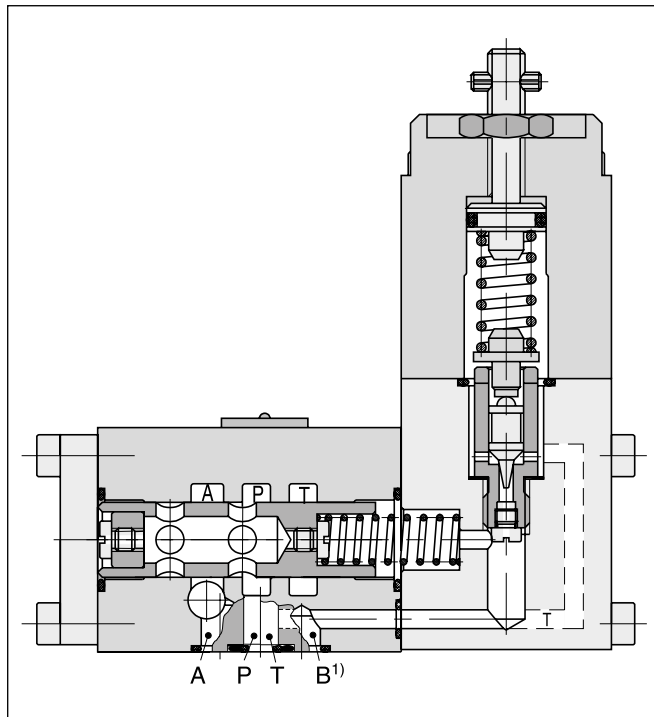

**VBY\*A10**

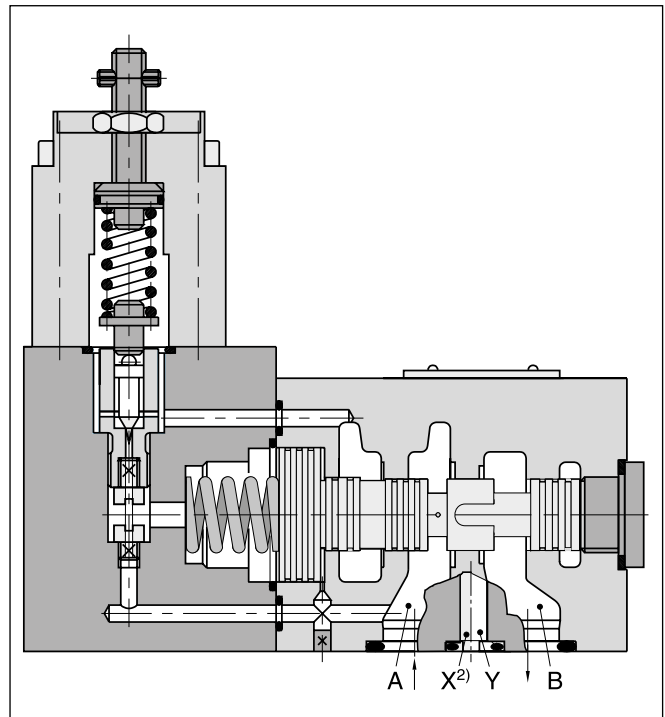

1) Port B for remote control, otherwise to be blocked.  
2) Port X for remote control, otherwise to be blocked.

**Ordering code**

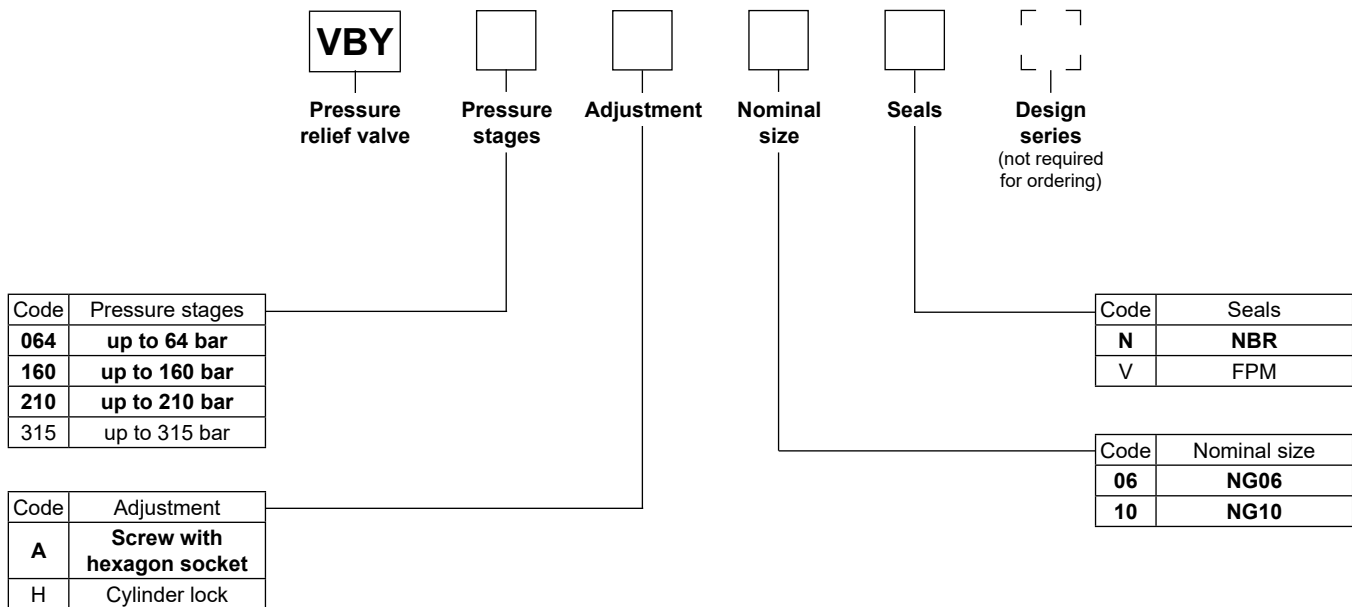

**Bold letters =  
Short-term availability**

**4**

**Technical data**

General	
Design	Pilot operated pressure relief valve, spool type
Nominal size	<b>NG06</b> <b>NG10</b>
Interface	Subplate mounting according to ISO 5781
Mounting position	unrestricted
Ambient temperature [°C]	-20...+60
MTTF <sub>D</sub> value [years]	75
Weight [kg]	2.4 4.5
Hydraulic	
Max. operating pressure [bar]	P, A 315, B blocked A, B 350, X blocked
External drain port pressure [bar]	T 100 Y 100
Pressure stages [bar]	64, 160, 210, 315
Fluid	Hydraulic oil according to DIN 51524
Fluid temperature [°C]	-20...+70 (NBR: -25...+70)
Viscosity, permitted [cSt] / [mm <sup>2</sup> /s]	20...400
Viscosity, recommended [cSt] / [mm <sup>2</sup> /s]	30...80
Filtration	ISO 4406 (1999); 18/16/13
Nominal flow [l/min]	See p/Q curves
Pilot oil flow [cm <sup>3</sup> /min]	approx. 500 approx. 1000

**p/Q performance curves NG06**

**Max. 64 bar**

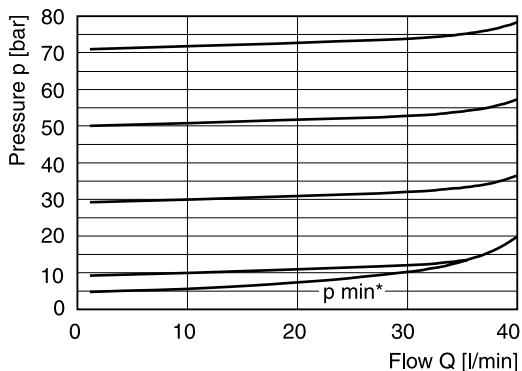

**Max. 160 bar**

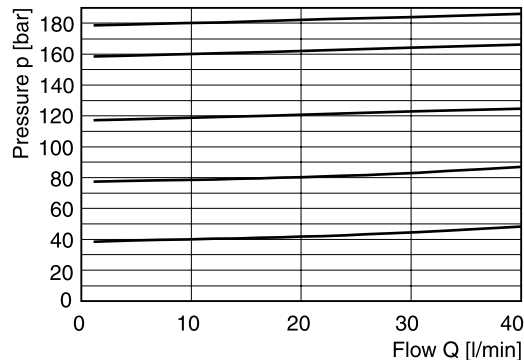

**Max. 210 bar**

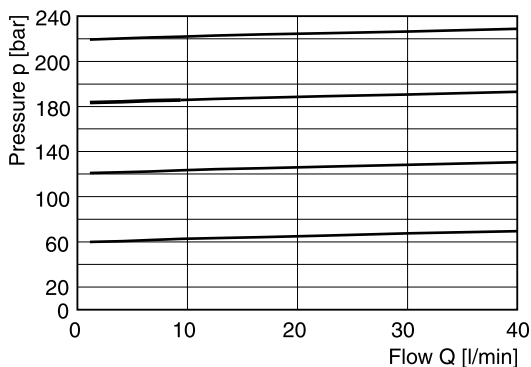

**Max. 315 bar**

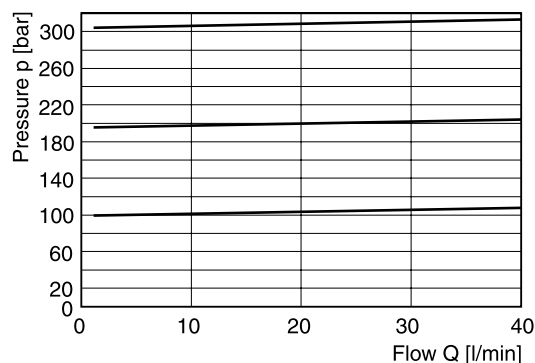

**p/Q performance curves NG10**

**Max. 64 bar**

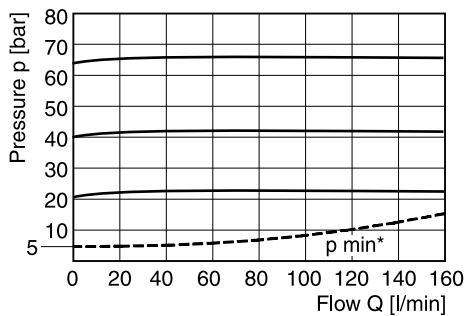

**Max. 160 bar**

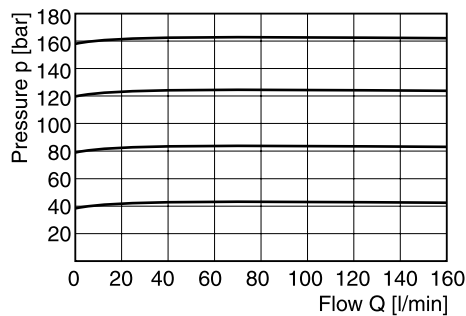

**Max. 210 bar**

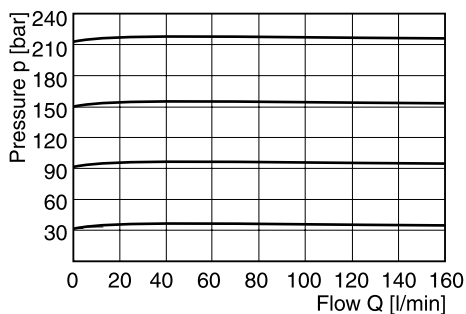

**Max. 315 bar**

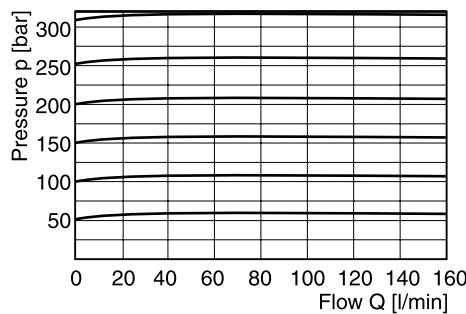

All characteristic curves measured with HLP46 at 50 °C.



\* For all pressure stages.

4

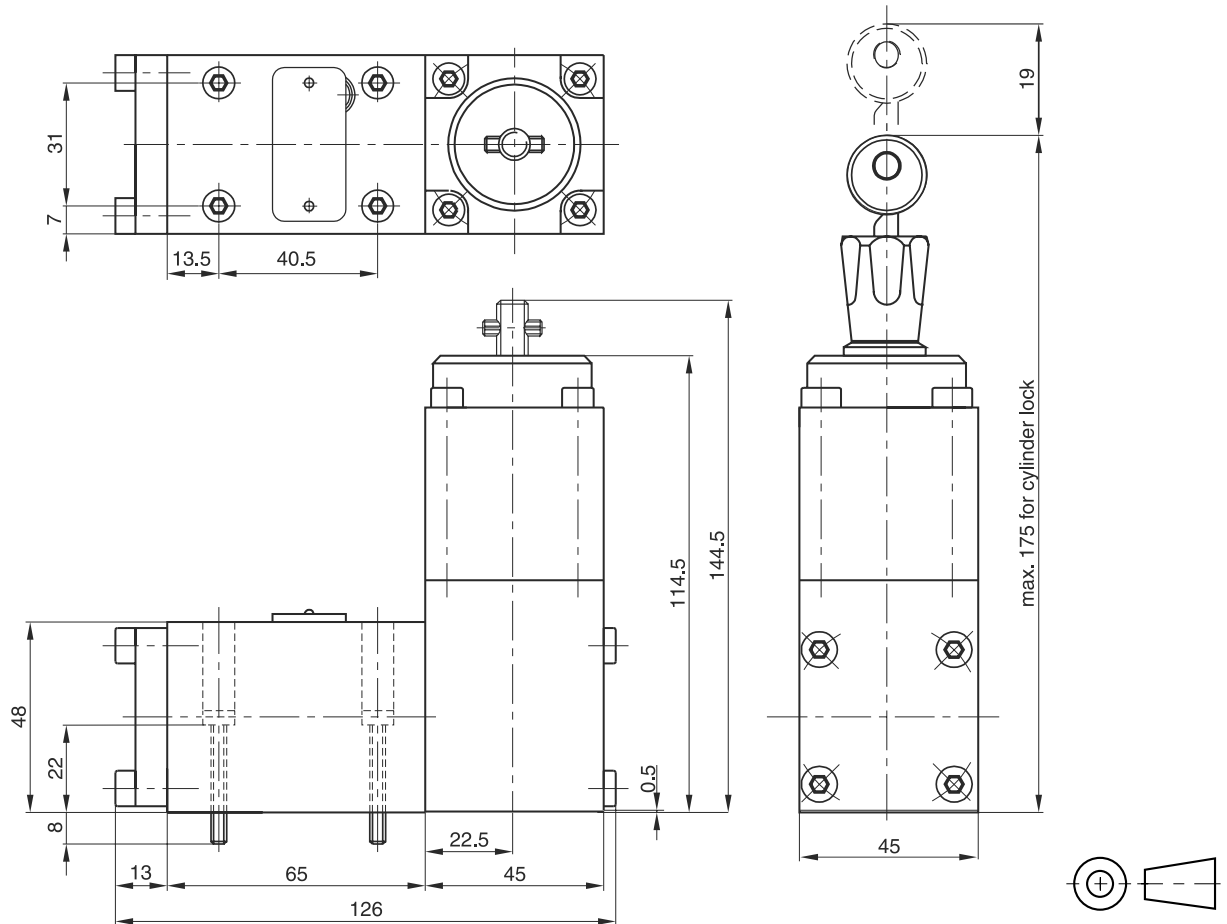
**NG06**

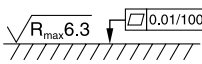

**4**

Surface finish	Bolt kit			 Kit FPM
	BK375	4x M5x30 ISO 4762-12.9	7.6 Nm ±15 %	SK-VBY-A06V

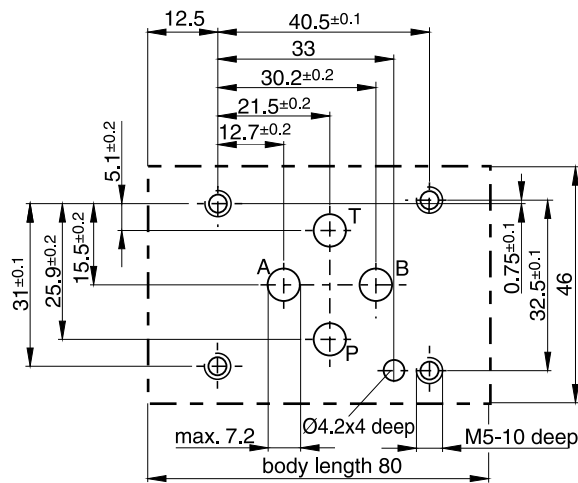

**Mounting pattern ISO 5781-03-04-0-00**

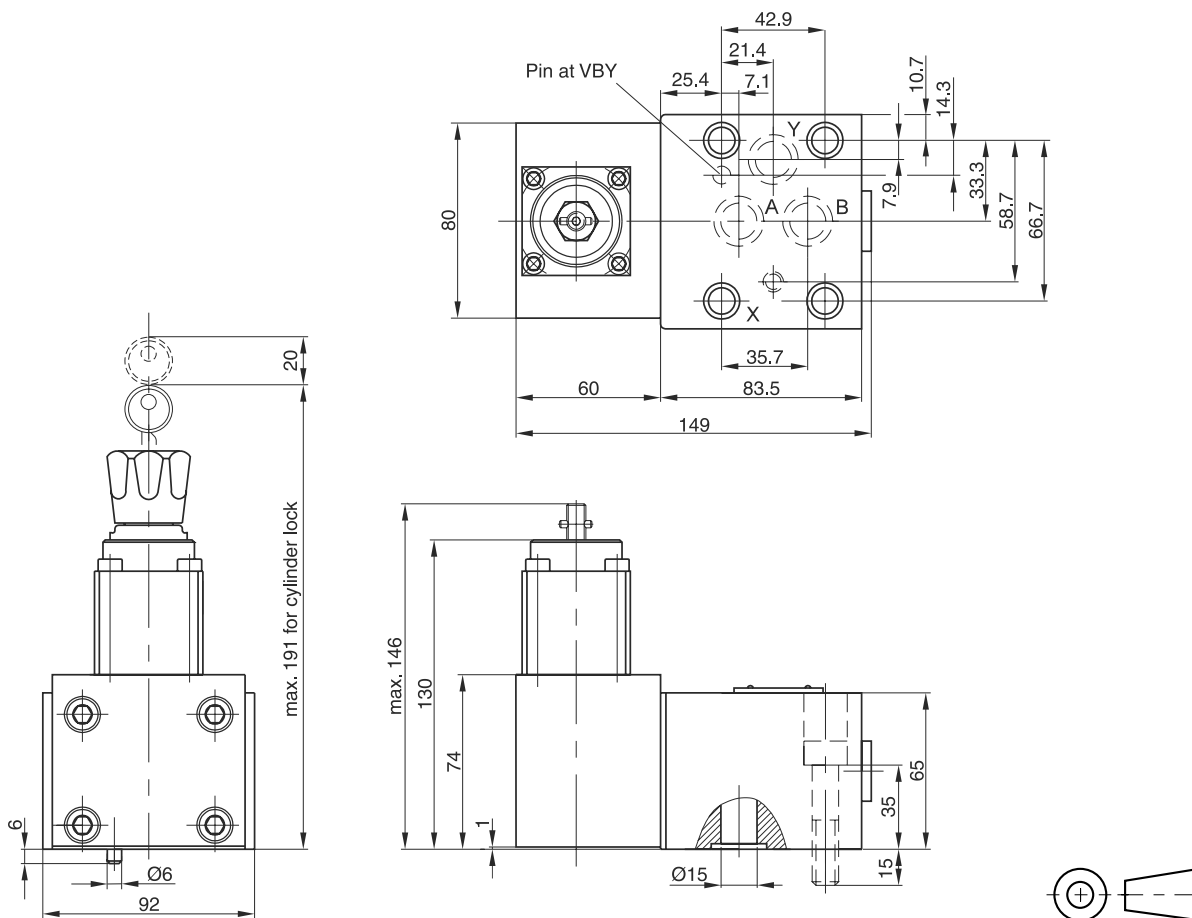

**NG10**

**4**

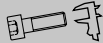

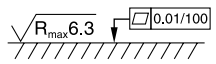
Surface finish	Bolt kit			 Kit FPM
	BK389	4x M10x50 ISO 4762-12.9	63 Nm ±15 %	SK-VB/VM-A10V

**Mounting pattern ISO 5781-06-07-0-00 <sup>1)</sup>**

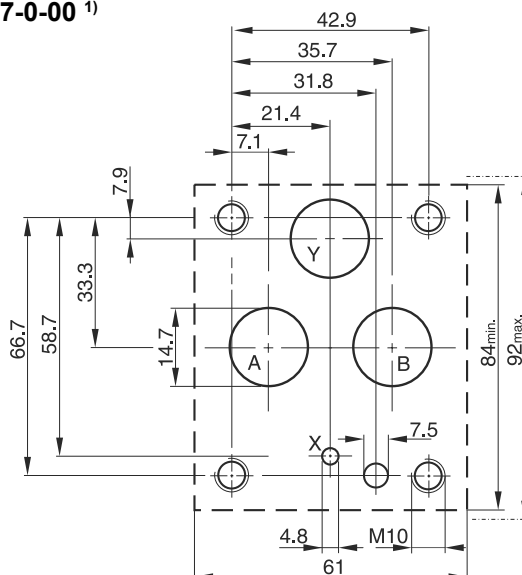

<sup>1)</sup> Deviating from ISO the Y port has Ø 14.7 instead of Ø 4.8.